

Schelling UK Ltd
 Osborne House
 Sandbeck way
 Wetherby
 LS22 7DN
 West Yorkshire

04/2021

Used ERBO Extraction System from IMA SCHELLING UK Ltd

As a result of the constant technological advances being made by sawing machine manufacturers, the demands placed on modern dust removal and filter systems are becoming ever greater. We have now an excellent used Erbo system in stock at our Wetherby Headquarters ready for shipping.

Details of this machine are below:

Technical data STA 700/15-4-AK:

Electrical power:	15KW
Vacuum at the machine:	35mbar
Air volume:	5000m ³ /h
Noise level:	approx. 78dB(A)
Colour:	RAL 7035
Build year:	2016

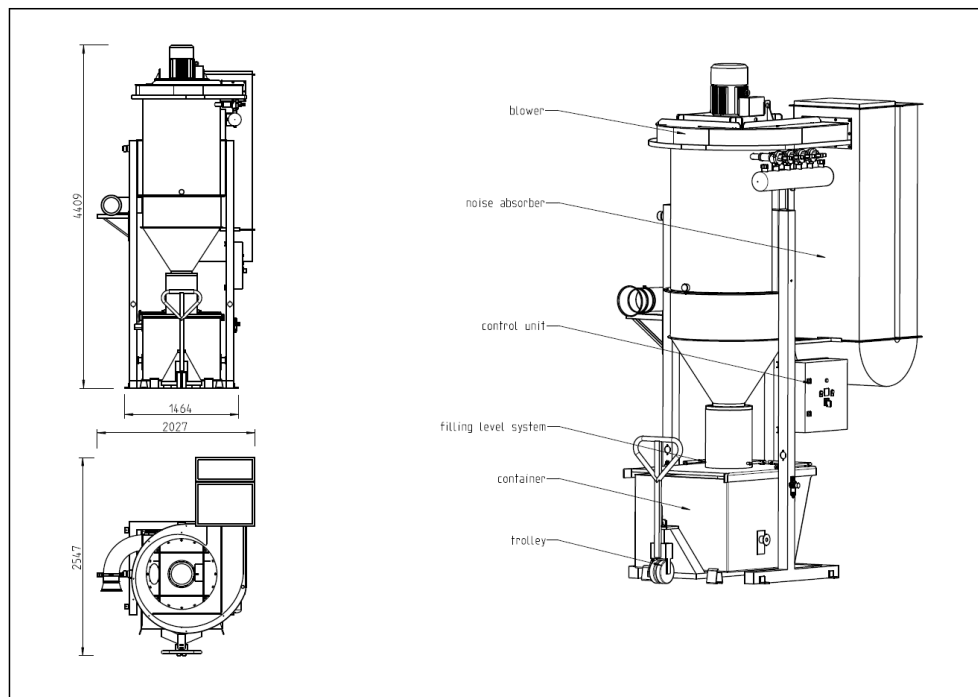



Price of System as described above:

GBP POA

Delivery: TBC

Warranty: 12 months

Payment: TBC

I will be pleased to answer any further questions you may have.

A handwritten signature in black ink, which appears to read "Markus Freuis".

Markus Freuis
IMA Schelling UK Ltd
Osborne House
Sandbeck way
Wetherby
West Yorkshire
LS22 7DN



IMA SCHELLING
GROUP